

Installation Manual for the **NuVAX 4400**

VAX Replacement System



Document Number MNL_MVX-4400_I1

Revision A, February 2015

VMS is a trademark of Hewlett Packard Corporation.

The material in this manual is for informational purposes only and is subject to change without notice.

Contents

- Chapter 1: Installation..... 5
 - Set up the System..... 5
 - System I/O and Controls..... 5
 - Verify NuVAX Runs MDM Diagnostics 6
 - Install the NuVAXplus Manager..... 8
 - Physical Disk Image Capture..... 9
 - Configure Option Module Address and Vectors 9
 - Create a NuVAXplus Configuration 9
- Chapter 2: General Description..... 11
 - Features 11
 - Option Modules..... 12
 - Specifications..... 12
 - System Unit..... 12
 - Ports 13
 - Performance 13
 - Compatibility..... 13
 - Front Panel LEDs..... 13
 - Environmental..... 13
- Chapter 3: Maintenance..... 14
 - Air Filter..... 14
 - System Battery Replacement..... 15
 - Reset Time and Date..... 16
 - Troubleshooting..... 17
 - Error Messages 17

Figures

Figure 1-1: NuVAX Front Panel	6
Figure 1-2: NuVAX Chassis Rear	6
Figure 2-1: NuVAX System Front View	11

Chapter 1: Installation

This chapter lists the steps involved in unpacking and setting up the NuVAX hardware and software. Installation consists of the following steps, each of which is described in this section or referred to another manual.

- Set up the system
- Power up the system and verify it runs the MDM system diagnostic
- Install the NuVAXplus Manager
- Use NuVAXplus to capture your physical disk and create a virtual disk
- Set address and vectors for all option modules (I/O controllers)
- Create a NuVAXplus configuration file with physical and emulated I/O controllers

Set up the System

Once the system is unpacked set it up as described below.

- Open the drive bay at the front of the chassis and remove the foam cushioning.
- Place the system on a table or bench in a well-ventilated area or mount the system chassis into a standard RETMA rack as described in the box with the chassis slides (MSC-3200).
- Connect the power cable that is located in the Accessory Box supplied in the box with the chassis.

System I/O and Controls

The system front panel is shown in Figure 1-1. The front panel provides access to power and reset switches, the data and system hard drives, DVD drive, fan filter, and the chassis cover access lock. Access the front panel by turning the thumbscrew at the center of the access door a quarter-turn counter-clockwise and lowering the access door.

Figure 1-2 shows the rear of the chassis with the location of USB, Ethernet, mouse, video, COM1 and LPT1 ports. The NuVAX option module I/O ports are available for connection at the rear of the chassis.

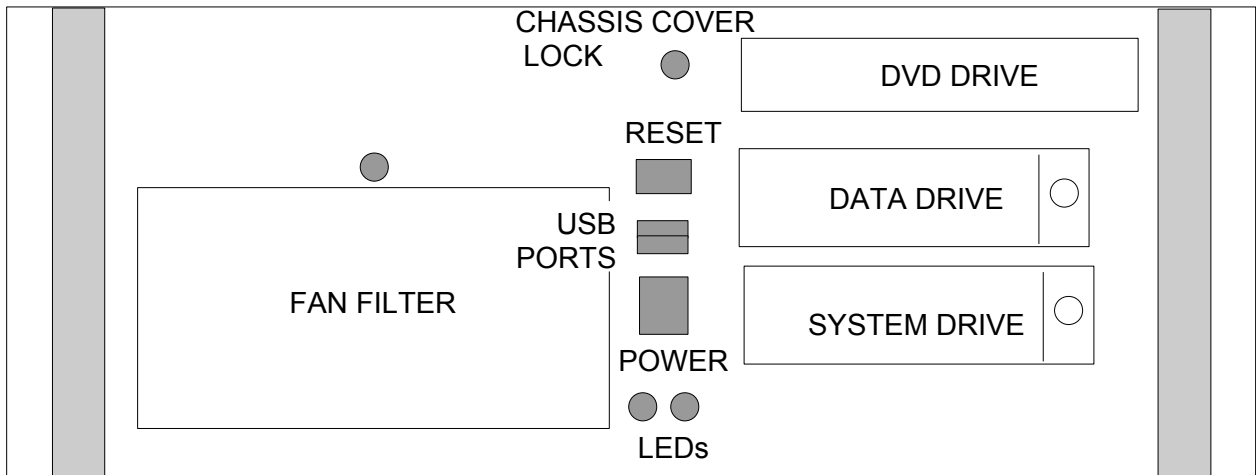

Note: The green LED indicates power is applied; the red LED indicates activity to/from the hard drives.

Figure 1-1: NuVAX Front Panel

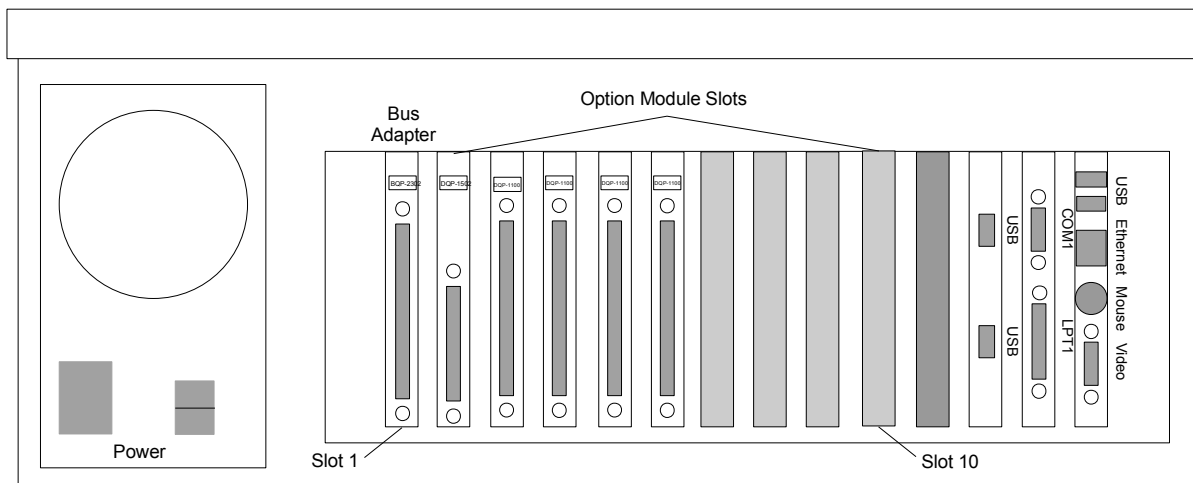

Figure 1-2: NuVAX Chassis Rear

Verify NuVAX Runs MDM Diagnostics

Diagnostics are used to verify that NuVAX functions correctly and reliably allow you to selectively test the functions of the VAX CPU, memory and most option modules. The NuVAX system is shipped ready to run MDM on the configuration tested before shipping.

Use the VAX console or a terminal emulator to validate that the system operates correctly.

VAX Console connection: Connect one of the serial port cables located in the Accessory Box to the serial port on the rear panel of the NuVAX chassis. Use CAB-2009-18 if the VTxx console has a 9-pin connection, or CAB-2010-18 for a 25-pin connection.

Terminal emulators or simple character terminals can plug directly into the NuVAX DE9 COM port using a standard cross-over cable and do not require an adapter cable.

The MDM diagnostic suite can be a useful tool when defining a NuVAX preventative maintenance program. Some modules are compatible with DEC's MDM diagnostics and each NuVAX system disk contains a bootable virtual disk with the complete suite of MDM diagnostics. Custom modules may be supplied with Logical's TREX diagnostic contained on a separate bootable CD. Consult the owner's manual of each option module to determine what diagnostic method is available. Follow the instructions below to boot MDM and run the system diagnostic.

Note: User input at the console is shown in bold print and the Return key is represented by [cr].

Apply power to the NuVAX and after about 30 seconds the VAX boot prompt, >>>, appears. Type **b mua0 [cr]**

After several seconds the MDM start-up banner appears and then it prompts for the date and time. It is not critical to set the date and time so just press the return key [cr].

Next it will ask for the mode of operation, type: **1 [cr]** to select the 'Menu Mode.'

At the 'Main Menu' type: **4 [cr]** to enter the 'Service Menu.'

At the 'Service Menu' type: **1 [cr]** to enter the 'Set test and message Menu.'

At the 'Set test and message Menu' type: **3 [cr]** to enable 'Stop testing on error.'

Next type **0 [cr]**, to return to the 'Service Menu'.

At the 'Service Menu' type: **3 [cr]** to enable the 'Device Menu.'

After all device drivers are loaded enter a [cr] and a device list is displayed.

Review the list of devices to determine which you do not wish to include in the testing.

It is best to disable the testing of **all mass storage devices** preventing the accidental destruction of important files.

Type the number of a device to disable and a Return, then type: **1 [cr]** to disable the testing.

Next type **0 [cr]**, to return to the 'Device Menu'.

When you have completed device disabling, type: **0 [cr]** this returns you to the 'Service Menu'.

At the 'Service Menu' type: **2 [cr]** to start the system exerciser. The program will pause and wait for confirmation for any device that requires that a loop-back be installed. Type **[cr]** to confirm the request or type a **Ctrl C** to stop the process and return to the 'Service Menu'. After loop-back confirmation completes, each device performs a function test and then all devices exercisers start and run concurrently until an error is encountered or testing is terminated by typing a **Ctrl C**.

Install the NuVAXplus Manager

The NuVAXplus Manager (Manger) is a Windows desktop application that provides a user-friendly interface to configure the NuVAXplus software for a particular hardware configuration so that it accurately emulates the system it is replacing. The Manager can start and stop the NuVAXplus Emulator and reboot the system during the setup and configuration process. Upload/download capability of disk and tape images provide a convenient method of backing up or restoring emulated mass storage devices.

A Help file document (NuVAXHelp.pdf) is provided on the CD with the NuVAXplus Manager. This file is also available from the Help menu of the program. The Help document explains how to use the Manager to create and manage configuration files to emulate a particular VAX system.

The steps below describe how to install the Manager software and the Help files.

Installation

To install and use the NuVAXplus Manager the following are needed:

- PC or laptop with Windows XP or Windows 7
 - NuVAXplus Manager installation disc (MED0178CD)
- A. To install NuVAXplus Manager onto a PC or laptop computer, insert MED0178CD disc in the CD/DVD drive and then run the **setup.exe** program.

Name	Date modified	Type
DotNetFX35SP1	2/5/2013 1:44 PM	File folder
WindowsInstaller3_1	2/5/2013 1:44 PM	File folder
NuVAX_Setup.msi	1/10/2013 4:44 AM	Windows Installer ...
NuVAXHelp.pdf	1/31/2013 8:06 AM	Adobe Acrobat D...
setup.exe	1/10/2013 4:44 AM	Application

The setup will walk you through the installation procedure.

An icon on the computer's desktop is added to open and use Manager.

- B. Copy and replace the NuVAXhelp.pdf file located in the folder where Manager was installed with the NuVAXHelp.pdf file provided in the MED0178CD. By default Manager is installed in:
- Windows XP and Windows 7 32-bit:
C:\Program Files\The Logical Company\NuVAX
 - Windows 7 64-bit:
C:\Program Files (x86)\The Logical Company\NuVAX

Physical Disk Image Capture

When you receive the NuVAX system, it does not contain an operating system. NuVAX can boot and run your VAX physical system disk or the disk contents can be moved to NuVAX's internal disk for booting and operation. Moving the VMS physical disk image to a NuVAX virtual disk image is a complex process. Because each VAX system has a unique mass storage configuration there is not a user manual available for physical to virtual disk capture. We recommend that only qualified VARs and technical people trained by VARs attempt this procedure.

Configure Option Module Address and Vectors

The option modules shipped in the NuVAX system are configured to the default addresses and vectors to run DEC diagnostics. If the interfaces in your VAX application are set to different addresses, any installed NuVAX option modules need to be set to match your application. Table 2-1 lists the DEC interfaces and their corresponding option modules.

Note:

The CCI-0008-A option module, which is used to emulate serial async devices, needs to be added in any configuration file using NuVAXplus Manager software.

- A. Determine the addresses/vectors of the interfaces in your VAX system.
- B. Using the manual for your option module, set the address and vectors to match.

The arrangement of physical option modules and the substitution of emulated disk, tape and network controller requires knowledge of DEC Qbus configuration rules and how they apply to a NuVAX containing both physical and emulated (virtual) I/O controllers. As with the physical disk capture, we recommend that only qualified VARs and technical people trained by VARs attempt this procedure.

Create a NuVAXplus Configuration

Consult the NuVAXplus manager manual, available by selecting Help topics under the manager Help menu, for creating and configuring NuVAXplus emulator and emulated I/O

(virtual) devices. A Manager Help menu screen shot is shown below. We recommend your initial VMS configuration be created by qualified VAR technical personnel.

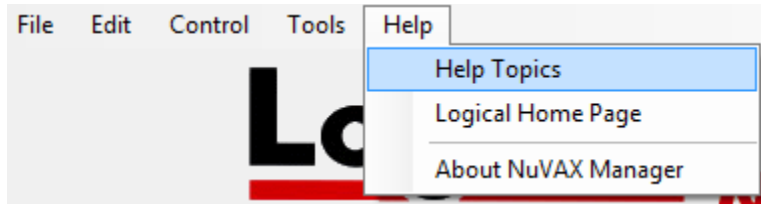

Chapter 2: General Description

The NuVAX is a complete hardware and software replacement for Digital Equipment Corporation's VAX computer systems.



Figure 2-1: NuVAX System Front View

Features

- NuVAX systems offer a removable SATA system drive and an optional removable data drive.
- Support up to 64MB of VAX memory.
- Support Fast Ethernet adapters for 10/100 Mbps network connections to other systems using network protocols like DECnet and TCP/IP.
- Offer a choice of special DEC-style interfaces, or option modules. Other interfaces can be custom designed for your application.
- Support speeds of more than 24 times the VAX speed.

Option Modules

DEC Interface	Option Module
DRQ3B	DQP-1500-AA Standard DQP-1500-AA Long Line
DRV11	DQP-1300-AA
DRV11-J	DQP-1400-AA
DRV11-WA	DQP-1100-AA Standard DQP-1100-AB Long Line
IEQ11-A	DQP-3100-AA
DHV11, DHQ11, DZQ11, CXY08	CCI-0008-AA
Adapter for External Unibus Support	AQP-2303-AA, 2 KW11-K

Table 2-1: Qbus Option Modules

Specifications

System Unit

Physical	Standard 4U rack-mount chassis (20" depth)
Weight	13.6 kg (30 lbs) representative system
Power	400 Watt ATX-12V 2.01 PS/2. Full range Active PFC.
Drive Bays	2 cartridge-style hard drives, one DVD drive
Hard Drives	Removable 320 GB SATA drives; one system drive*, one data drive
VAX Memory	512 MB, up to 128 MB used for VAX memory
Clock	KWV11-C standard, or optional KW11-K emulation
I/O Slots	9 available

* Virtual drives are limited to 2 GB maximum size.

Ports

Ethernet	Two ports, one port DELQA/DEQNA emulation, one port for NuVAXplus Manager
RS232 Serial Port	COM1 Console (TTY) only
Baud Rates	50, 75, 110, 134.5, 150, 300, 600, 1200, 1800, 2000, 2400, 4800, 7200, 9600, 19.2K, 38.4K bits/sec
Data bits	5, 6, 7, 8
Stop bits	1, 1.5, 2
Parity	Odd, even, or no parity
USB	Not supported by VAX
Printer Supported	LPV11

Performance

Standard	Up to 24 VUPS
----------	---------------

Compatibility

Processors Supported	MicroVAX II, MicroVAX 3300, 3400, 3500, 3600, 3800, 3900, and 4000
Disks Emulated	RQDX3, KDA50
Tapes Emulated	TQK50, TQK70
Ethernet Emulated	DEQNA, DELQA

Front Panel LEDs

Red	Indicates activity on the hard drives
Green	Indicates that system power is on.

Environmental

Operating Conditions:	
Temperature	10° to 40° C (50° to 104° F)
Relative Humidity	20% to 80% non-condensing
Storage Conditions:	
Temperature	-40° to 60° C (-40° to 140° F)
Relative Humidity	10% to 95% non-condensing

Chapter 3: Maintenance

This section provides basic maintenance information for your NuVAX system. The NuVAX system is designed for low-maintenance, trouble-free operation. Two areas require attention from time to time:

- Keep the air filter clean as described below, and minimize dust when possible.
- The CMOS battery on the motherboard lasts from 2-10 years depending upon operating temperature and the amount of time the system is turned off. Higher temperatures and long periods when the system is turned off shorten the battery life. The battery needs replacement when the system no longer keeps the current time.

Air filter maintenance and battery replacement are described in the following sections.

Air Filter

Clean the fan air filter as often as necessary to prevent overheating due to reduced air movement. When reinstalling the air filter, make sure the filter material does not reduce the airflow within the chassis or overheating may become a problem. Generally, dust poses no danger to a computer, except for disk drives. Conductive dust, however, such as metal or carbon particles, can be problematic.

To replace the air filter, do the following:

- 1) Remove power to the system.
- 2) To access the air filter, release the front panel door by turning the quick-release screw at the center of the panel clockwise.



- 3) The fan filter is on the left side of the chassis. Access the filter by turning the quick-release screw at the top of the filter access door.



- 4) Gently remove the filter from the inside of the fan filter access area.



- 5) Clean the air filter. The filter can be blown out or washed in soapy water. Make sure the filter is completely dry before reinstalling.
- 6) Close the fan filter access door, tighten the quick-release screw, close and lock the front panel.

Note: Filters do not remove fumes or gases. Do not use the chassis in environments where airborne contaminants may damage the system.

System Battery Replacement

The battery is a standard CR-2032 battery that can be purchased anywhere batteries are sold. The expected lifecycle depends on a variety of factors, but a minimum of several years of battery life can be expected..

To replace the battery:

- 1) Remove power to the system.
- 2) Open the front panel door turning the thumb screw at the top, center of the access door one-quarter turn counter-clockwise.
- 3) Unlock the chassis cover using the round thumb screw at the center of the front panel (to the left of the DVD drive). Turn the thumbscrew counter-clockwise.



- 4) Slide the chassis cover back to remove.
- 5) Remove the hold down bracket to allow access to the battery.
- 6) The battery is located two inches or so behind the Ethernet ports and approximately two inches below the SATA ports (near the heatsink) of the CPU board.

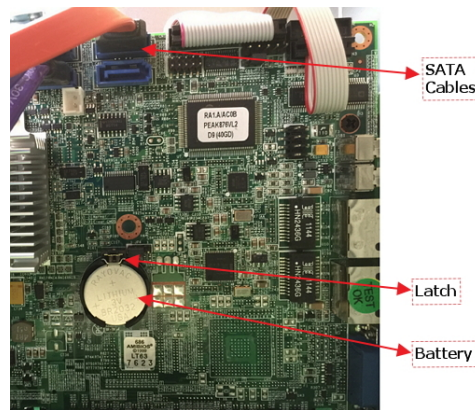

- 7) To remove the battery, find the wire latch located at 12 o' clock on the battery, then push it away from the battery until the battery pops out. Be careful when working next to the SATA cables. If you remove the cables for better access, be sure to mark them so that you can replace them in their original positions.
- 8) Install a new battery with 'CR2032' facing up. Dispose of the used battery according to the battery manufacturer's instructions.
- 9) Replace the hold-down bracket and chassis cover and secure. Close the front panel access door.

When the battery is removed, the time of day and date are lost. Enter the CMOS Bios as described in the next section to reset the time and date.

Reset Time and Date

To re-set the BIOS settings, you need a VGA monitor and USB keyboard.

- 1) Connect the monitor and keyboard to the back of the system chassis.
 - a. Connect the keyboard to a USB port.
 - b. Connect the monitor to the 15-pin blue VGA connector and power on the monitor.

- 2) Power on the system and press 'F1', when prompted, to enter setup and change the date and time.

Troubleshooting

If the NuVAX system does not boot properly, it may be due to a failed battery. Refer to previous section on how to replace the battery. Determine if this is the cause of the failure by attaching a VGA monitor and USB keyboard. If a new battery and BIOS settings does not resolve the problem, call your VAR for assistance.

Error Messages

Any error messages indicate a failure. Call your VAR for assistance.



75 Gateway Blvd.
Cottage Grove, Oregon 97424 USA
<http://www.logical-co.com>

Telephone: +1 541-942-3610
Fax: +1 541-942-3640
E-mail: sales@logical-co.com