

## DQP-3100

### IEQ11 Compatible IEC/IEEE Option Module for NuVAX



The DQP-3100 PCI-based option module works with Logical's NuVAX 3000 and 3100 systems to allow users to migrate from a Qbus system to a PCI-based system while maintaining their investment in software and user equipment.

The DQP-3100 installs into one PCI slot and requires only DC power from the slot. When used for dual channel operation, a second I/O panel slot is required. The DQP-3100 connects to the NuVAX bus adapter and, optionally, other PCI-based Qbus option modules by way of a top-edge flat ribbon interconnect cable.

The DQP-3100 is a DMA controller that interfaces a Qbus system to two independent channels that are compatible with both the IEC and IEEE instrument buses. The instrument buses conform to both the European Standard IEC 625-1 and the U. S. Standard IEEE 488.1-1987. Each instrument bus can have up to fifteen devices, including the DQP-3100, in a sequential configuration.

Each independent channel of the DQP-3100 provides system controller, controller-in-charge, talker, and listener capabilities. Termination of data transfers are by E.O.I., byte count, or by match characters.

**IEEE and IEC Compatible.** The DQP-3100 supports both the U.S. standard IEEE-488.1 and European IEC 625-1 standards.

**Two Independent Channels.** The DQP-3100 supports two independent channels providing flexibility for a variety of applications.

**Software Compatible.** The DQP-3100 is application and diagnostic compatible providing a direct replacement for the IEQ11-A.

**Hardware Compatible.** The DQP-3100 is signal and connector compatible to Digital's IEQ11-A allowing use of existing Digital cables and panels.

**Switch Compatible.** Switch settings are identical to the IEQ11-A switches for ease of use.

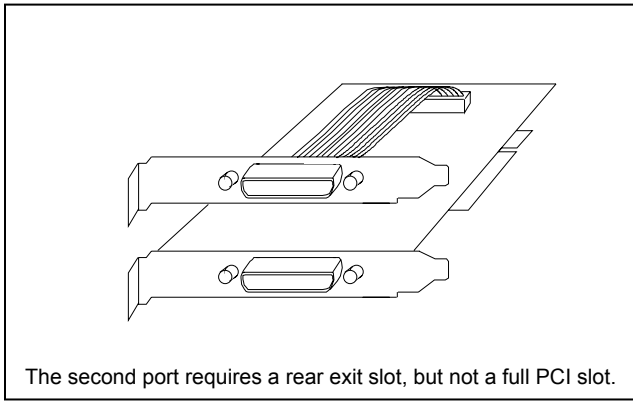

## Specifications

### Physical Dimensions

PCI Controller PCI short card, +5 volt only, measuring 6.88 in by 4.20 in (17.46 cm by 10.67 cm)

### Connectors

IEEE IEEE-488 standard 24-pin connector  
IEC IEC-625 standard 25-pin connector

### Electrical

Power Required: DQP-3100 0.5 amps @ 5.0 volts  
±12 volts not used  
IEC/IEEE Bus Load 1 on each bus

### Performance Parameters

Operating Modes: 1. Programmed I/O transfers with interrupt.  
2. DMA data transfer, byte addressing, and interrupt.

Transfer Rate: Up to 150K bytes per second (DMA transfer). Transfer rates depend on the hardware configuration and operating system.

Maximum Block Length: 64K bytes

Addressable Memory Range: 4MB (Q22)

Interrupt Vector: Vector A (channel 1) is selectable, while Vector B (channel 2) depends on Vector A. Vector B is set at A+4.

Priority Level: BIRQ4

### IEC/IEEE Bus Parameters

Communication Channel Two independent IEC/IEEE buses  
Number of Devices Up to 15 devices on each bus including DQP-3100  
Maximum Cable Length Two meters (6.56 ft) times the number of devices, or 20 meters (65.6 ft), whichever is less

### PCI Local Bus

Signaling Universal +3.3 volt and + 5 volt  
Addr/Data 32-bit  
Clock Rate 33 MHz  
Compliance 2.1

MTBF 65,000 hours

### Environmental

Operating Conditions:  
Temperature 5° to 50° C (41° to 122° F)  
Relative Humidity 20% to 80% non-condensing

Storage Conditions:  
Temperature -40° to 66° C (-40° to 150° F)  
Relative Humidity 10% to 95% non-condensing

## Ordering Information

DQP-3100-AA PCI IEEE option module with QP interconnect cable, IEC to IEEE488 cables, and owners manual. Requires two rear panel exit slots for two-line operation.

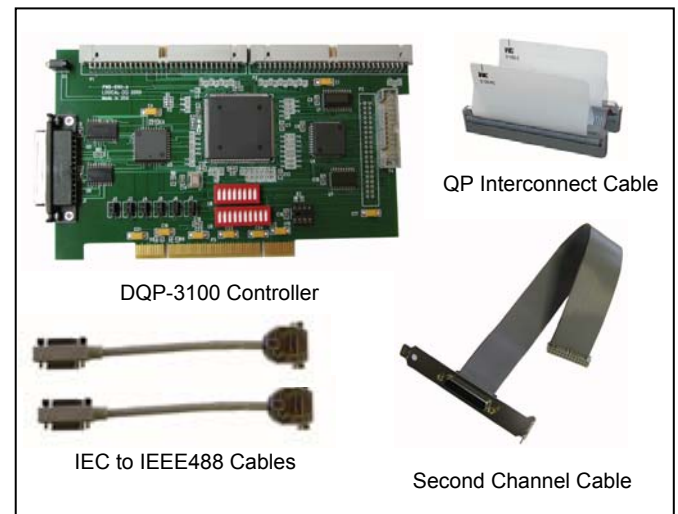

Digital and Qbus are trademarks of Hewlett Packard Corporation. We reserve the right to improve our products without notice.